

# Welding device for automotive parts

**Usage** A mechanism that moves the welding torch of welding device for steel pipes at a constant speed.

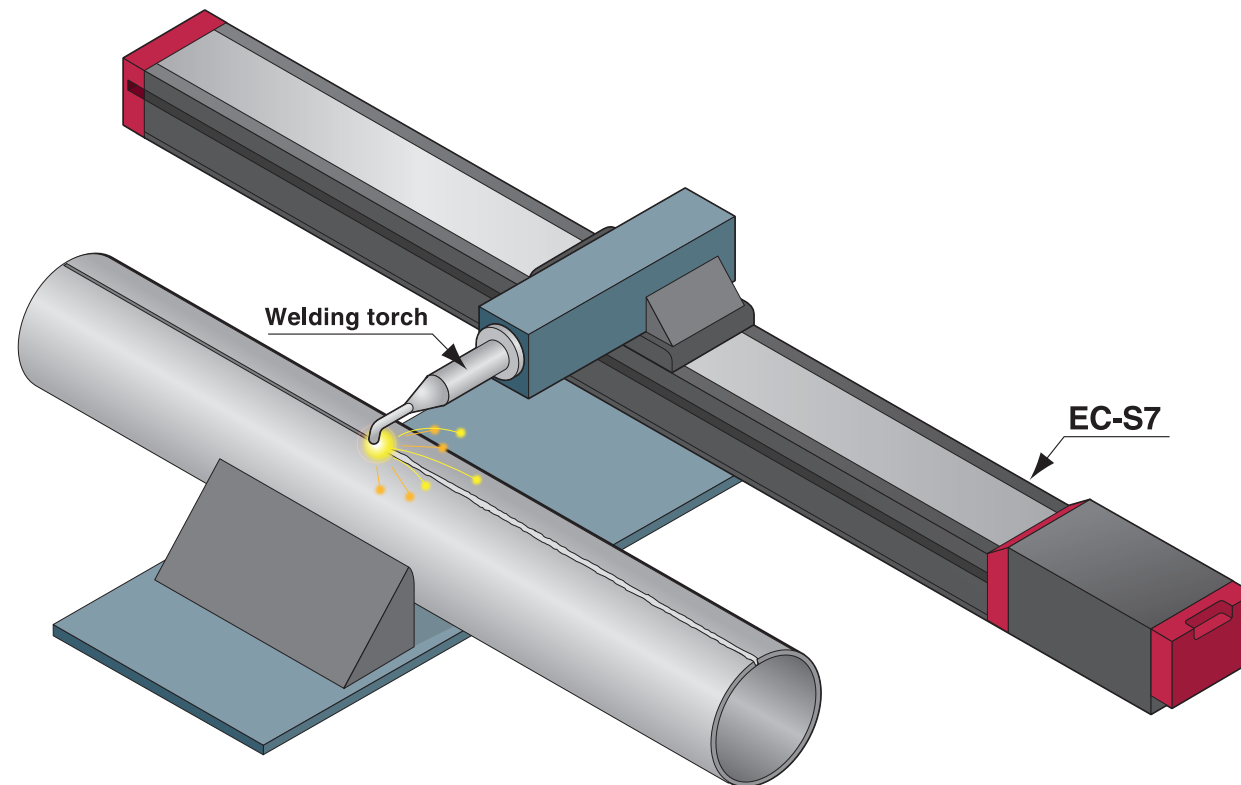

## Explanation

Conventionally, this process was carried out manually and the quality was not consistent. Adopting the Elecylinder enabled the movement speed to be in constant, resulting in stable product quality. Since the speed can be easily changed, fine adjustments can be made while viewing the product status. By using the Elecylinder, not only is it easy to operate, but it is also inexpensive. Since the speed can be changed easily, fine adjustment of the welding width can be done in a short period of time. Furthermore, the Elecylinder is also inexpensive and easy to use.